



Part of GE's Sensing & Inspection Technologies business

RHM 80

Coriolis Mass Flowmeter for Large Flow Applications Optional Heavy Duty Version

The RHM 80 can measure flow rates up to 480 t/hr with the patented Omega shape meter technology manufactured by rheonik, the mass flowmeter experts.

Applications

- Loading of boats, vessels, rail road tank wagons
- High temperatures and other challenging applications
- Highly viscous media (low pressure drop and excellent performance at low flow conditions)

Features

- As heavy duty version available (increased wall thickness of measuring pipes for additional safety - 160 bar)
- Flow Accuracy better than 0.2%
- Repeatability better than 0.05%
- Patented torsion swinger
- Customer adaptations possible for application optimized solutions

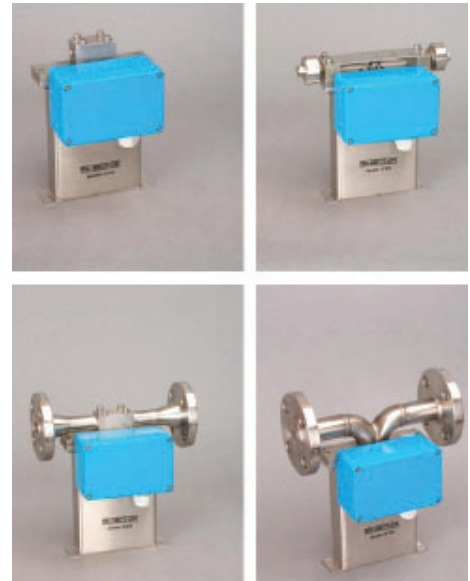

- Typical measuring ranges from 1 60 to 8000 kg/min
- EEx Approvals (i.e. ATEX, CSA, ...)
- Custody Transfer Approvals (i.e. PTB, NMI, ...)

Advantages

- High flow rates for fast filling
- Patented torsion swinger design assures most stable and drift free measurement
- Increased signal to noise ration by torsion swinger
- Longest life time and increased safety (low stress in welds and increased wall thickness against abrasion)
- No moving parts, practically no maintenance



General

The RHM 80 has been designed for medium flow rates and tough application conditions. Optional heavy duty measuring pipes make this meter suitable for applications involving corrosive media at high temperature.

This unique design, which offers excellent performance and reliability, has created the most satisfied customers worldwide. Unlike other mass flowmeter manufacturers, Rheonik uses a patented torsion rod swinger with the Omega shape and support bars which results in high accuracy measurement, which is independent of pressure, even at very low flow velocities. The meter also has extremely good repeatability and high stability for critical applications.

RHM 80 Specifications

Performance RHM 80

Max Flow 8000 kg/min (17635 lb/min)

Standard Models			
Rates/turndown ratio	in (kg/min)	in (lb/min)	error in % of reading
nominal rate Q_{nom}	5000	11025	0.20
$0.2 * Q_{max}$ (5:1)	1600	3528	0.20
$0.1 * Q_{max}$ (10:1)	800	1764	0.20
$0.05 * Q_{max}$ (20:1)	400	880	0.20
$0.02 * Q_{max}$ (50:1)	160	353	0.50

Typical ΔP in bar (psi)		
1 cP	100 cP	1000 cP
0.4 (5.7)	0.8 (11.6)	2.0 (28)
0.1 (0.7)	0.1 (1.1)	0.6 (8)
~ 0 (0.1)	~ 0 (0.4)	0.2 (3)
~ 0 (0)	~ 0 (0.2)	0.1 (2)
~ 0 (0)	~ 0 (0.1)	0.1 (1)

Optimized Low Flow Models/optimized to be operated between $0.0165 * Q_{max}$ and $0.325 * Q_{max}$			
Rates/turndown ratio	in (kg/min)	in (lb/min)	error in % of reading
$0.325 * Q_{max}$ (1:1)	2600	5732	0.15
$0.0325 * Q_{max}$ (10:1)	260	572	0.20
$0.0165 * Q_{max}$ (20:1)	130	286	~ 0.50 ^(*)

0.1 (0.6)	0.2 (3.8)	1.0 (14)
~ 0 (0)	~ 0 (0.1)	0.1 (1)
~ 0 (0)	~ 0 (0)	~ 0 (0)

(*) around 0.30 - 0.70 % accuracy depending on the installation conditions

Gold Line Models/application fine tuned meters			
$1 * Q_{nom}$ (1:1)			
$0.1 * Q_{nom}$ (4:1)			
$0.05 * Q_{nom}$ (8:1)			

0.4 (5.7)	0.8 (11.6)	2.0 (28)
~ 0 (0.4)	~ 0 (0.8)	0.5 (6)
~ 0 (0.1)	~ 0 (0.4)	0.2 (3)

Repeatability

better $\pm 0.05\%$ of rate

Density

better than ± 0.0015 g/cc - Gold Line: Field adjustable to better ± 0.001 g/cc

Temperature

Better $\pm 1^\circ\text{C}$

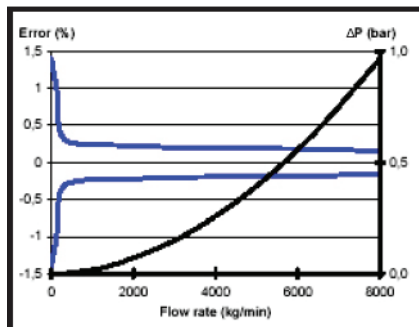

Standard Models

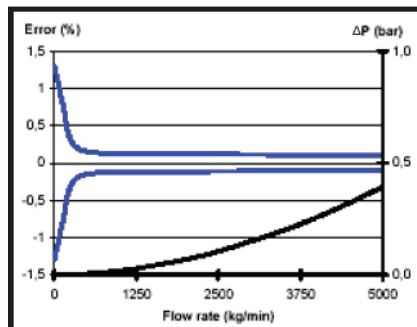

Gold Line Models

Data above refer to standard wall thickness.

Error of reading (including zero drift) indications refer to reference conditions H_2O , 18°C to 24°C (66°F to 76°F), 1 bar to 3 bar (15 psi to 45 psi).

RHM sensor do not suffer from pressure effect due to torsional oscillation and semi circle (non-deforming) measurement section.

Temperature changes of $\pm 25^\circ\text{C}$ around the operating point are negligible.

Pressure drop refers to Newton liquids.

Nominal flow refers to approx. 10 m/s (33 ft/sec) velocity in measuring loops for best performance.

Calibration to customer range, with increased accuracy, possible.

General Outline Dimensions RHM 80

Type II (sealless welded parallel measuring loops w/o sealings [PF0])

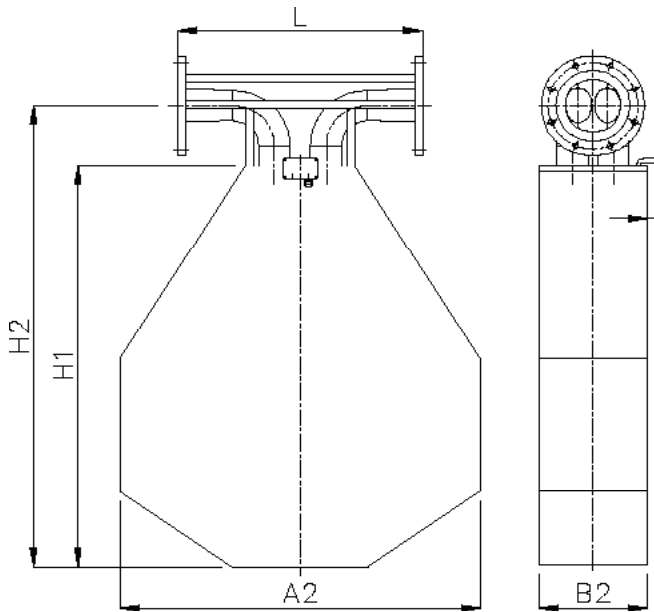

A2 = 1320 mm (51.96 in)
 B2 = 403 mm (15.86 in)
 H1 = 505 mm (59.25 in)
 H2 = 775 mm (69.88 in)
 W = 50 mm (5.91 in)

Weight: approx. 380 kg (838 lb)

Shipping box: approx. 220 x 160 x 90 cm (87 x 63 x 36 inch)

Process Connection	Face to Face Length (L) ^(*)	Order Code
6 in CL 150 acc. ANSI B16.5	900 mm (35.43 in)	A1
6 in CL 300 acc. ANSI B16.5	900 mm (35.43 in)	A2
Standard 6 in CL 600 acc. ANSI B16.5	900 mm (35.43 in)	A3
DN150/PN16 acc. DIN 2527 - C	900 mm (35.43 in)	D1
DN150/PN40 acc. DIN 2527 - C	900 mm (35.43 in)	D2
6 in CL 900 acc. ANSI B16.5	900 mm (35.43 in)	A7
Optional 6 in CL 500 acc. ANSI B16.5	900 mm (35.43 in)	A9
DN150/PN100 acc. DIN 2527 - E	900 mm (35.43 in)	D3

(*) Customization possible on request.

The finish type of our ANSI flanges is RF/SF (AARH 125-250 (µinch) - Ra 3,2 up to 6,3 (µm)). Others available on request.

Above table only shows our general process fittings.

For further customization with regard to special fittings and face to face length please contact your local agent.

General Specifications RHM 100

Approvals

- ATEX (CESI 02 ATEX 053 X):
- Ex II 1 G, EEx ia IIC T6-T1
- CSA (220705) Class I, Div 1 and 2, Groups A, B, C and D; Type 3
- Custody Transfer Approvals (PTB 1.32-97027224 and NMI TC 3382)
- PED according to directive 97/23/EC available

Electrical Connection

- Junction box/aluminium coated (standard) IP 65 (Nema 4X) (Junction box in SS optional)
- Cable entry M25 x 1.5 (M20 x 1.5, ½ in and ¾ in NPT optional)
- Max cable length between RHM and RHE: 100 m (330 ft) 200 m (660 ft) only with factory approval

Housing

- Stainless Steel: 1.4301/SS 304
- others on request -
- Protection class: IP 65 (Nema 4X)
- higher on request -

Material of Wetted Parts

- 1.4571/SS 316Ti (standard)
- 1.4539/SS 904L on request
- Hastelloy C22 on request
- Other material on request

Pressure Rating

- Pressured part of the meter consists of the measuring loops and the connection part. The weaker of both parts decides the maximum allowed operating pressure. Below is the max. operating pressure of the measuring loops(*).

(* These values are only valid for SS 316Ti & SS 904L materials. Statements for others materials on request.

Standard Version:

- 100 bar @ 120°C (1450 psi @ 248°F)
- 90 bar @ 210°C (1305 psi @ 410°F)
- 75 bar @ 350°C (1085 psi @ 662°F) wall thickness is generally 4.05 mm (0.16 in)

Optional High Pressure Version:

- 160 bar @ 120°C (2320 psi @ 248°F) wall thickness is generally 6.3 mm (0.25 in)

Other Pressure Rating

- on request -

Temperature Rating

- NT Models from -20°C to 120°C (-4°F to 248°F)
- ET Models from -45°C to 120°C (-49°F to 248°F)
- ET1 Models from -200°C to 50°C (-328°F to 22°F)
- ET2 Models from -45°C to 210°C (-49°F to 410°C)
- HT Models from 0°C to 350°C (32°F to 662°F)

Order Code RHM 80

Order Code Structure

The order code of the Rheonik Sensors consists of 6 sections (see previous pages/below). Restrictions of combinations may apply. For specials, please comment your needs in plain text/sketches.

Temperature Rating

- T1** NT Models (Normal Temperature Models) from -20°C to 120°C (-4°F to 248°F)
- TA** ET Models (Extended Temperature Models) from -45°C to 120°C (-49°F to 248°F)
- T2** ET2 Models (Extended Temperature Models) from -45°C to 210°C (-49°F to 410°F)
- T3** ET1 Models (Extended Temperature Models) from -200°C to 50°C (-328°F to 122°F)
- T4** HT Models (High Temperature Models) from 0°C to 350°C (32°F to 662°F)

Pressure Rating

- P1** Standard pressure version (100 bar @ 120°C/1450 psi @ 248°F) - page 4 -
- P2** High pressure version (220 bar 120°C/3190 psi @ 248°F) - page 4 -
- PX** Other pressure version (on request) - page 4 -

Construction Type

- PF0** Parallel Measuring Loops Seal Less Welded Version - page 3 -
- XXX** Other construction type on request

Material of Wetted Parts

- M1** 1.4571/SS 316Ti
- M2** 1.4539/SS 904L
- M3** Hastelloy C22

Process Connection

- XX** Code available on page 3.

Hazardous Area Approvals

- NN** Without Ex Approvals
- AT** ATEX Approvals (CESI 02 ATEX 053 X) - Ex II 1 G, EEx ia IIC T6-T1
- CS** CSA Approvals (220705) - Class 1, Div 1/Group A, B, C, and D; Type 3

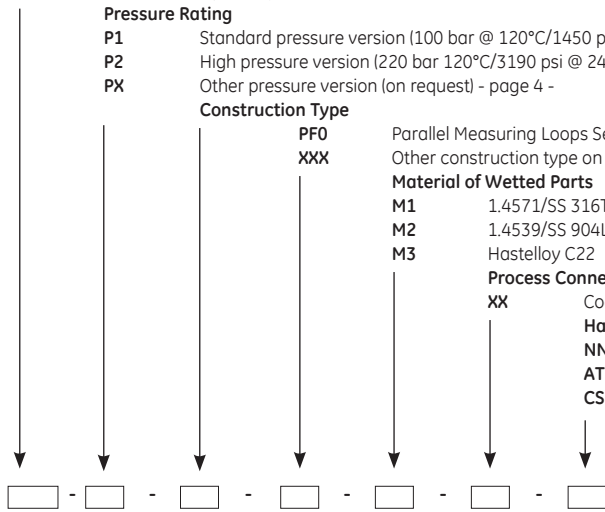

Order Code Example

M#80 T1 P1 PF0 M1 A2 AT

- T1:** NT (Normal Temperature Models) from -20°C to 120°C (-49°F to 248°F)
- P1:** Standard pressure version (100 bar @ 120°C/1450 psi @ 248°F)
- PF0:** Parallel Measuring Loops Seal Less Welded Version
- M1:** 1.4571/SS 316 Ti
- A2:** 6 in CL 300 acc. ANSI B 16.5
- AT:** ATEX Approvals (CESI 02 ATEX 053 X)

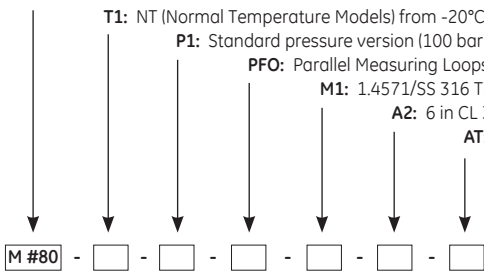



EX-CALIBRA

Autoryzowany dystrybutor

GE Measurement & Control Solutions

41-400 Mysłowice, ul. Portowa 25

tel.: 32 2239280, fax: 32 2239281

e-mail: ex-calibra@ex-calibra.pl

Internet: www.ex-calibra.pl

www.gesensinginspection.com

920-###-1